



RECEIVED
3/17/2026

COMMONWEALTH OF PENNSYLVANIA
DEPARTMENT OF ENVIRONMENTAL PROTECTION
OFFICE OF OIL AND GAS MANAGEMENT

DEP USE ONLY
Application Tracking # 1562670

Proposed Alternate Method or Material for Casing, Plugging, Venting or Equipping a Well

Well Operator Keystone Land Resources		DEP ID# 69252	Well Permit or Registration Number 37-059-01626	
Address 46226 National Road		358023	Well Farm Name W Johnson 3	
City St. Clairsville	State OH	Zip Code 43950	Well # M-1848	Serial #
Phone 740-338-3100	Fax	County Greene	Municipality Springhill	

A proposed alternate method is subject to provisions in §3221 of the 2012 Oil and Gas Act, 58 Pa. C.S. §3221 Section 13 of the Coal and Gas Resource Coordination Act, 58 P.S. §513 and 25 PA Code §§78.75-78.75a (relating to Alternate Methods.) Attach proof of notification of coal operator(s).

Describe in reasonable detail using a written description and / or diagram:

- 1. the proposed alternate method or materials, and**
- 2. the manner in which the alternative will satisfy the goals of the laws and regulations.**

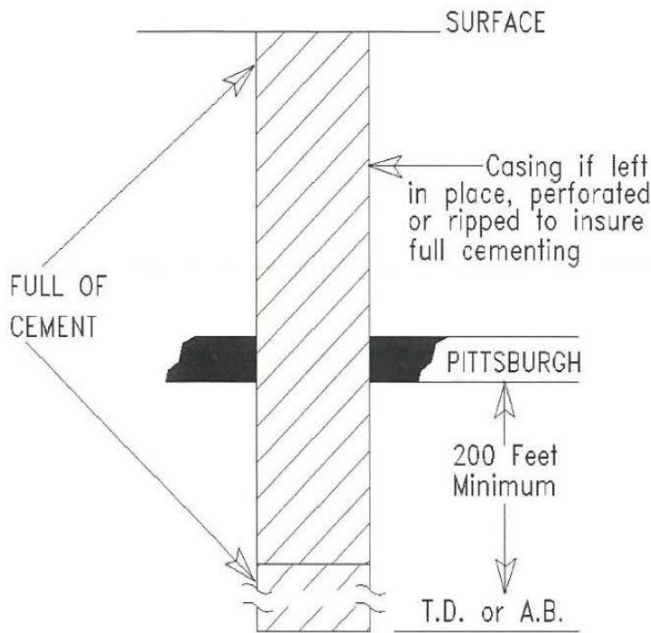

1. All available well records are attached.
2. The well bore will be cleaned to a total depth (T.D.) or DEP approved attainable bottom (A.B.). That portion of the borehole that is cleaned out to a depth greater than 200 ft. below the coal to be mined will be plugged in accordance with State Regulations 78.91, 78.92, and 78.93. The proposed alternate method of plugging the well bore will address only that portion of the well bore from a maximum of 200 ft. below the coal to be mined to the surface.
3. From 200 ft. below the coal to be mined to the surface all casing will be removed to a minimum of a single string. Any casing remaining will be perforated at 50 ft. intervals.
4. If the casing cannot be removed through the coal to be mined, it will be section milled or fully ripped from 10 ft. below the bottom of the coal seam to 10 ft. above the top of the coal seam.
5. Logging will include Gamma-Neutron, Caliper Survey and a Directional Deviation Survey.
6. Tubing will be run into the well to a point approximately 10 ft. above the T.D. or DEP approved A.B. of the hole. The hole will be filled to the surface with fluid gel of sufficient weight to suppress gas emissions. Portland cement will be pumped from T.D. or A.B. to 200 feet or more below the workable coal seam. The hole will then be cemented from there to 100 feet above the workable coal seam with an expandable cement. The remainder of the hole will be filled with Portland Cement mixture. In lieu of venting requirements, the well will be plugged solid from T.D. or DEP approved A.B. A steel plate indicating the well API #, Serial #, plugged date, and well operator will be placed over the well bore and placed on a minimum 6 foot high post or buried a minimum of 3 feet under the finished ground.
7. If it becomes necessary to deviate from the proposed alternate method, in that portion of the borehole from a maximum of 200 ft. below the coal to be mined to the surface, approval must be received from the district oil and gas inspector, regional oil and gas inspector supervisor, regional compliance manager, or regional manager and the coal operator affected. A letter will be attached to the plugging certificate stating the approved changes and the official who approved them.

Optional: Approval by Coal Owner or Operator		Signature of Applicant / Well Operator	
Signature <i>Jay Hores</i>	Date 3/17/26	Signature <i>Jay Hores</i>	Date 3/17/26
Print or Type Signer's Name and Title Jay Hores Project Engineer		Print or Type Signer's Name and Title Jay Hores Project Engineer	

If optional approval is signed by coal owner or operator, the 15-day objection period may be waived.

DEP USE ONLY	
Approved by (DEP Manager) 	Conditions <input type="checkbox"/> YES, See Attached <input checked="" type="checkbox"/> NO
	Date 4/24/26



DEP	Auth ID #	G: G:
USE	Permit #	
ONLY	Project #	

WELL LOCATION PLAT

PAGE 1 Surface Location

Denotes location of top of well on topo map. Well is located on topo map 7,781 feet south of latitude 39° 47' 30"

True Latitude: NORTH				
39	°	46	'	13.38"
True Latitude: WEST				
80	°	26	'	33.73"

WELL LOCATION
NAD83, PA. SOUTH
N: 170,751.688
E: 1,211,678.596

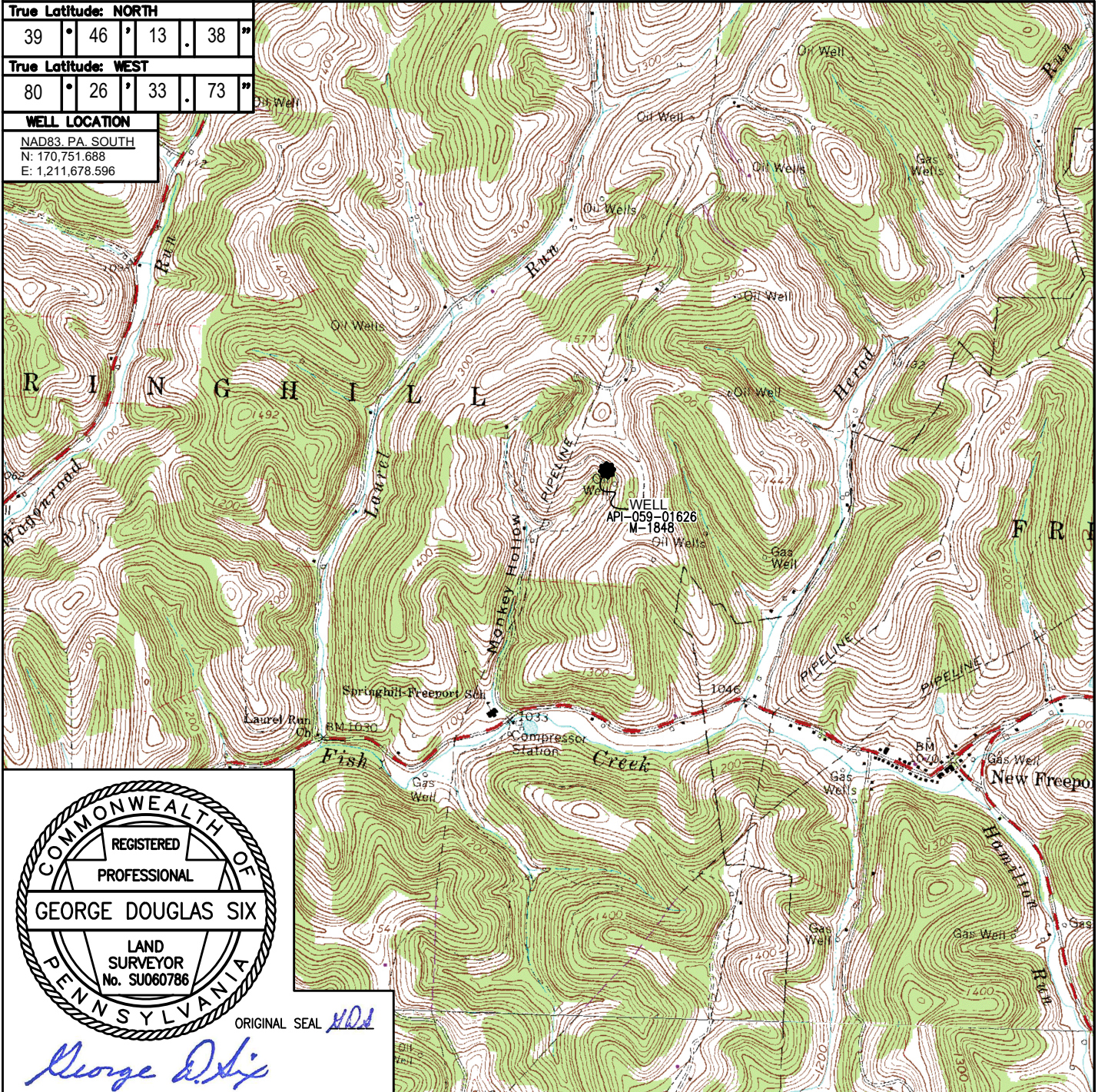

Well is located on topo map 7,379.9 feet west of longitude 80° 25' 00"

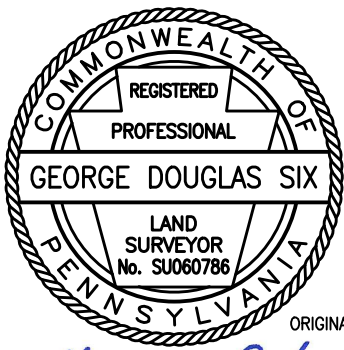

Applicant/Well Operator Name: KEYSTONE LAND RESOURCES		DEP ID #	Well (Farm) Name: W. JOHNSON #3		Well #: M-1848	Serial #:
Address: 46226 NATIONAL ROAD, ST. CLAIRSVILLE, OH 43950			County: GREENE	Municipality: SPRINGHILL	Well Type: GAS	
911 address of well site: NOT APPLICABLE			USGS 7½' Quadrangle Map Name: NEW FREEPORT, PA	Map Section: 8	Surface Elevation: 1309.20 ft.	
Surveyor or Engineer: GEORGE D. SIX P.L.S. SU060786	Phone #: (304)-662-6123	Dwg #: M-1848	Date: 11/03/2025	Scale: 1" = 2,000'	Tract Acreage: 113.8 ACRES	
Lat. & Long Metadata Method: G.P.S.	Accuracy: 1/100,000 ft.	Datum: NAD83 PAS	Elevation Metadata Method: G.P.S.	Accuracy: 1/100,000 ft.	Datum: N.A.V.D. 88	Survey Date: 12/21/2023