

RECEIVED
2/20/2026

COMMONWEALTH OF PENNSYLVANIA
DEPARTMENT OF ENVIRONMENTAL PROTECTION
OFFICE OF OIL AND GAS MANAGEMENT

DEP USE ONLY
Application Tracking # 1559884

Proposed Alternate Method or Material for Casing, Plugging, Venting or Equipping a Well

Well Operator Johnson J C		DEP ID# OGO-21805	Well Permit or Registration Number 37-125-90645	
Address UNKNOWN		69858	Well Farm Name WD Hutchinson	
City UNKNOWN	State UNK	Zip Code UNKNOWN	Well # W-1	Serial # W-1
Phone UNKNOWN	Fax UNKNOWN	County Washington		Municipality West Finley Township

A proposed alternate method is subject to provisions in §3221 of the 2012 Oil and Gas Act, 58 Pa. C.S. §3221 Section 13 of the Coal and Gas Resource Coordination Act, 58 P.S. §513 and 25 PA Code §§78.75-78.75a (relating to Alternate Methods.) Attach proof of notification of coal operator(s).

Describe in reasonable detail using a written description and / or diagram:

- 1.the proposed alternate method or materials, and
- 2.the manner in which the alternative will satisfy the goals of the laws and regulations.

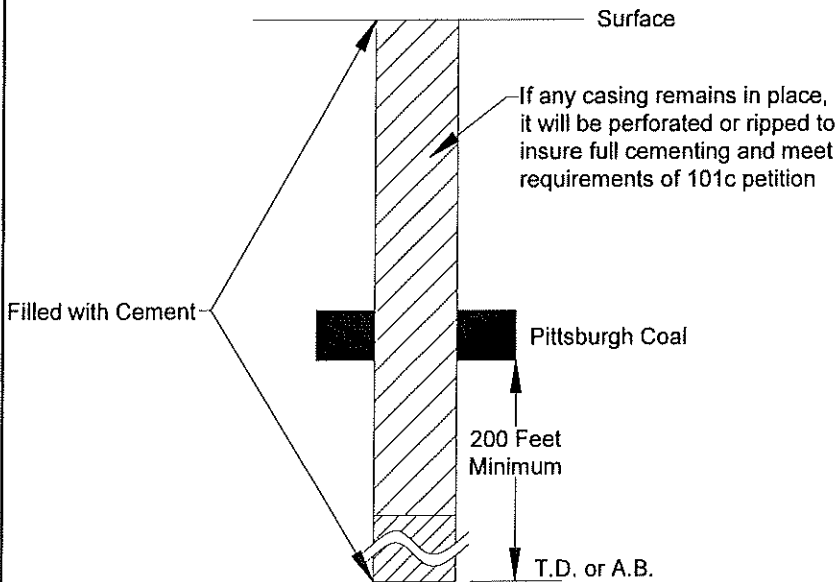

1. All available well records are attached.
2. The well bore will be cleaned to a total depth (T.D.) or attainable bottom (A.B.). The portion of the borehole that is cleaned out to a depth greater than 200 feet below the Pittsburgh 8 coal seam will be plugged in accordance with State Regulations 78.91, 78.92, and 78.93. The proposed alternate method of plugging the well bore will address only that portion of the well bore from a maximum of 200 feet below the Pittsburgh 8 coal seam to the surface.
3. From 200 feet below the Pittsburgh 8 coal seam to the surface, any remaining casing will be removed or perforated at a minimum of 50 foot intervals.
4. If the casing cannot be removed through the Pittsburgh 8 coal seam, it will be section milled, perforated, or ripped from 10 feet below the coal seam to 10 feet above the coal seam, at intervals not to exceed 5 feet.
5. Logging will include Gamma-Neutron, Caliper Survey, and a Directional Deviation Survey
6. Tubing will be inserted into the well to a point approximately 10 feet above the T.D. or A.B. of the well bore. The well bore will be filled to the surface with a fluid gel of sufficient weight to suppress potential gas emissions. Portland cement will be pumped from T.D. or A.B. to 200 feet or more below the Pittsburgh 8 coal seam. The well bore will then be cemented from that point to 100 feet above the Pittsburgh 8 coal seam with a non-shrinking cement. The remainder of the well bore will be filled with a Portland Cement mixture.
7. A steel plate indicating the well API #, Serial #, plugging date, and well operator will be placed over the well bore and buried a minimum of 3 feet under the finished ground.
8. If it becomes necessary to deviate from the proposed alternate method, that portion of the well bore from a maximum of 200 feet below the Pittsburgh 8 coal seam to the surface, approval must be received from the district oil and gas inspector, regional manager, and the coal operator. A letter will be attached to the plugging certificate stating the approved changes and the official who approved them.

Optional: Approval by Coal Owner or Operator		Signature of Applicant / Well Operator	
Signature 	Date 2/20/2026	Signature 	Date 2/20/2026
Print or Type Signer's Name and Title Evan Midler, Manager of Land, Environmental and Gov't Affairs		Print or Type Signer's Name and Title Evan Midler, Manager of Land, Environmental and Gov't Affairs	

If optional approval is signed by coal owner or operator, the 15-day objection period may be waived.

DEP USE ONLY		
Approved by (DEP Manager) 	Conditions <input type="checkbox"/> YES, See Attached <input checked="" type="checkbox"/> NO	Date 5/4/2026